

Lumiglas Light/Sightglass Luminaire Series MV-SLM

- for use with screwed sightglass fittings -

ISO 9001

DATA SHEET 02-0130 09/06

Applications:

This integral light/sight port has a weld-on sightglass fitting with a screwed cover flange which holds luminaire and sightglass simultaneously. It is designed to illuminate and to view into process vessels, silos, mixers, separators, pipelines, and other usually closed containers. This model is intended for use in all Non Hazardous Areas. The unit is particularly suitable for pharmaceutical, food and beverage processing, e.g. in breweries, dairies etc.

Sightglass Styles and Size:

This unit is available in sightglass sizes DN 65 to DN 125.

Protection:

When correctly fitted, dust and waterjet proof to IP 65, EN 60598.

Operating Conditions

Pressure: 90 psi (higher pressure ratings on request), vacuum

Temperature: Sightglass: max. 280°C (see temperature diagram)

Luminaire: 80 °C at the cable gland

Electrical Data:

- power supply 24 V (120 V on larger sizes)
- 2-pin halogen lamp 20, 50 or 100 W depending on size
- 2-pin socket GY 6.35

Switch/Pushbutton:

MV-SLM type luminaires are manufactured with built-in pushbutton.

Transformers:

Transformers can be supplied optionally (separate units).

Parts & materials: (drawing on the right)

Items	Parts name	Material options
1	luminaire SLM	
1.3	flat seal w. bridge	silicone, KLINGERSil C-4400
2.1	slotted cover nut	stainless steel 1.4301 (304)
2.3	sightglass disc	soda lime glass, tempered, max temp 150°C; or borosilicate glass, tempered, max. temp 280°C
2.4	ring seal (alternative)	Viton, PTFE, Buna, Silicone
2.5	weld neck	stainless steel 304; 316L
3	vessel wall	

Assembly and electric connection:

Please see overleaf.

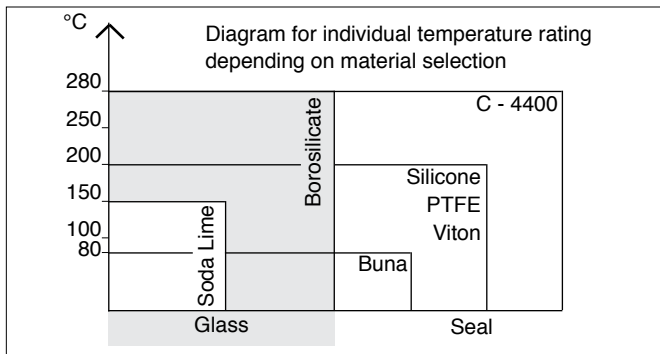

Complete unit Lumiglas MV-SLM

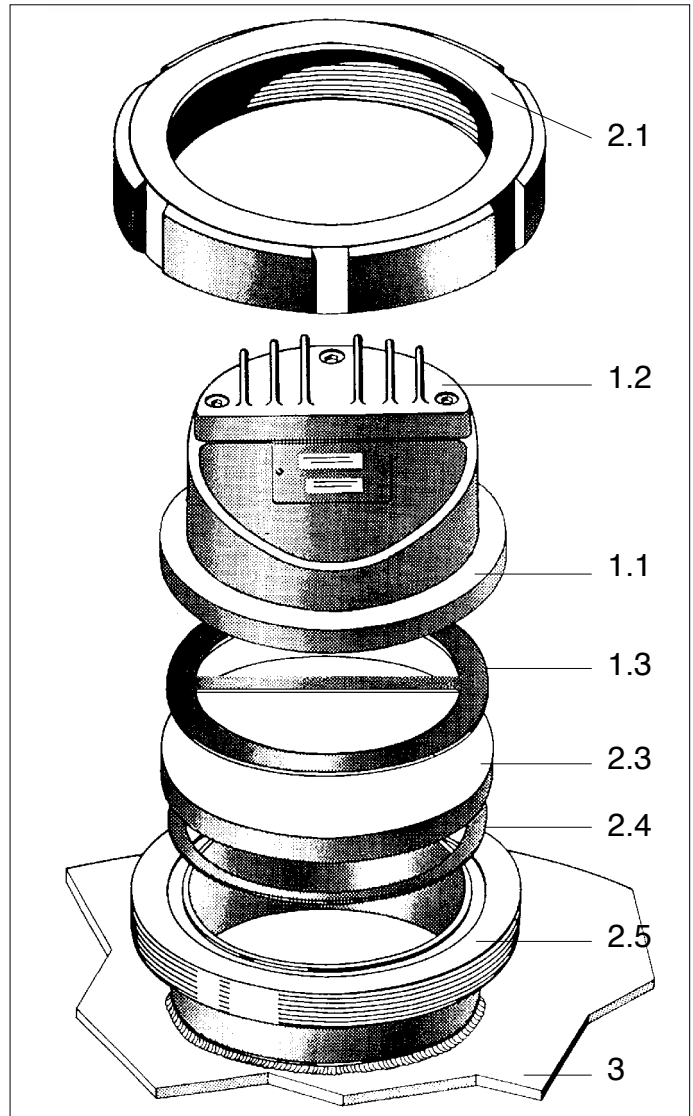

Exploded view of a Lumiglas MV-SLM combined light/sightglass unit.

ISO 9001 QA CERTIFICATE
GERMAN MANUFACTURER:
F.H. PAPPENMEIER AWARDED QA APPROVAL CERTIFICATE



Dimensions, mechanical and electrical data of Lumiglas Light/Sightglass Assembly Series MV-SLM

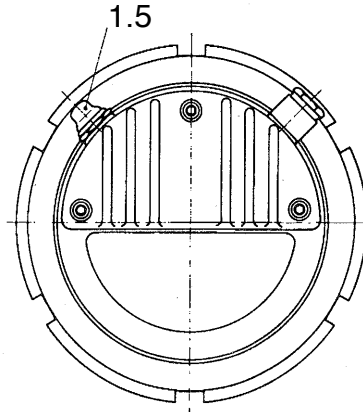
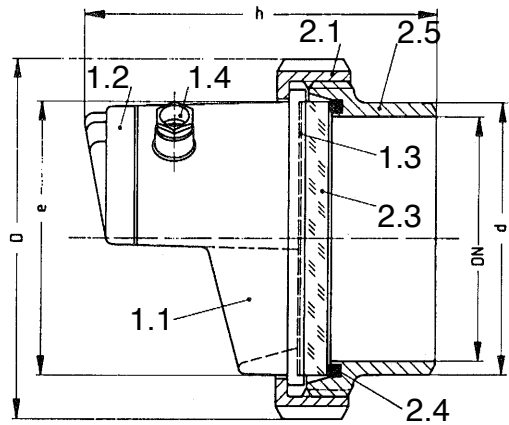

- 1.1 luminaire housing
- 1.2 cover
- 1.3 flat gasket w. bridge
- 1.4 cable gland
- 1.5 switch w. separ. sealing cap
- 2.3 sightglass disc
- 2.4 O-ring seal
- 2.5 weld neck
- 2.1 slotted cover nut

Parts, Construction and Materials:

- Luminaire body: Corrosion resistant die cast aluminium, painted silver-grey (RAL 9007)
- Suitable for food processing
- Luminaire cover (1.2) is screwed to luminaire housing (1.1) with inserted flat flexible gasket to form the connector box. A built-in switch with separate sealing cap (1.5) for intermittent use is standard. Electrical connection through cable gland (1.4) to inside terminals 2.5 mm².

Ordering Information:

Please state for example: Lumiglas Light/Sightglass Unit MV 80 / SLM 80 H / 24V - 20 Watt

Size		1	2	3	4
Lumiglas luminaire	type	MV 65 / SLM 65 H	MV 80 / SLM 80 H	MV 100 / SLM 100 H	MV 125 / SLM 125 H
Compatible with screwed sightglass fitting to DIN 11851 or similar	DN*	65 (2-19/32")	80 (3-7/32")	100 (4")	125 (7-7/16")
Voltage (optional Voltage)	V	24	24	24 (120)	24 (120)
Wattage	W	20	20	50	50 or 100 (24V only)
Dimensions	D	112 (4-1/2")	127 (5")	148 (5-3/32")	178 (7-1/8")
	d*	79 (3-5/32")	93 (3-3/4")	114 (4-1/2")	137 (5-1/2")
	e	78	92	113	136
	h	110	135	153	150

All dimensions in mm unless stated otherwise
 Subject to change without prior notice
 * Use mm dimensions for accuracy

Assembly:

Please note: Electrical connection should be carried out only after the mechanical fitting, Lumiglas luminaire 1 and flat seal 1.3 are bonded at the factory and come as a unit. After welding nozzle 2.5 into the vessel wall 3, fit O-ring seal 2.4, glass disc 2.3 and luminaire 1.1 as shown in the drawing overleaf. Tighten all parts down against the nozzle by cover nut 2.1.

Always use the special "C-Spanner". Finally check, if the sightglass disc sits correctly in the fitting.

Electrical Connection:

- Select correct type of cable to suit operating conditions
- Select cable diameter to suit cable gland
- Loosen lamp box cover screws and remove cover
- Pass cable through gland, and fit bared ends into terminal block
- Tighten cable gland
- Fit undamaged gasket and lid, tighten screws

Instructions for Lamp Change

with sightport unit not under pressure/temperature :

- switch off the luminaire
- loosen and lift off cover nut and luminaire
- withdraw defective lamp
- replace halogen lamp with lamp of same type and size, use protective cloth/paper to ensure bare fingers do not touch the glass, insert into 2-pin socket hole and gently but firmly push in
- refit and tighten luminaire cover nut
- switch power to ON

with sightport unit under pressure/temperature :

- switch off the luminaire
- open cover (see part 1.2 sketch above) loosen the lamp holder thus exposed in lampbox (part 1.1)
- withdraw holder complete with defective lamp
- remove lamp and replace as described above
- refit holder and lamp in light box
- replace gasket and luminaire lid and tighten screws
- switch power to ON

LJSTAR

PO Box 1116 • Twinsburg, OH 44087 • (330) 405-3040 • Fax 405-3070

INCORPORATED

E-mail: view@ljstar.com • Website: www.ljstar.com